

**Driver LC 38W 900mA fixC T SNC**  
essence in-track series (1-phase system)

**Product description**

- Constant current / in-track LED Driver
- Optional accessory ACU ALU NIPPLE M10x1 for mounting the luminaire head
- Compatible 1-phase system in-tracks, see data sheet chapter 3.8
- For luminaires of protection class II
- Temperature protection as per EN 61347-2-13 C5e
- Max. output power 38 W
- Up to 90 % efficiency
- Nominal life-time up to 100,000 h
- 5-year guarantee

**Housing properties**

- Casing: polycarbonat, black, white or grey
- Type of protection IP20

**Functions**

- Overload protection
- Short-circuit protection
- No-load protection

**Typical applications**

- For spot light in retail and hospitality application



**Standards**, page 4

**Wiring diagrams and installation examples**, page 4



Black (RAL 9005)



Grey (RAL 7035)



White (RAL 9010)



IP20 SELV      

### Driver LC 38W 900mA fixC T SNC

essence in-track series (1-phase system)

#### Technical data

Rated supply voltage	220 – 240 V
AC voltage range	198 – 264 V
Max. input current (at 230 V, 50 Hz, full load)	0.21 A
Leakage current (at 230 V, 50 Hz, full load)	< 50 µA
Mains frequency	50 / 60 Hz
Overvoltage protection	320 V AC, 48 h
Max. input power	44 W
Typ. power consumption (at 230 V, 50 Hz, full load)	42 W
Min. output power	27 W
Max. output power	37.8 W
Typ. efficiency (at 230 V / 50 Hz / full load)	90 %
λ (at 230 V, 50 Hz, full load)	0.95
Output current tolerance <sup>①</sup>	± 7.5 %
Max. output current peak <sup>②</sup>	1,016 mA
Output $P_{S+LM}$ (at full load)	≤ 1
Output SVM (at full load)	≤ 0.4
Max. output voltage (U-OUT)	50 V
THD (at 230 V, 50 Hz, full load)	< 15 %
Output LF current ripple (< 120 Hz)	± 5 %
Starting time (at 230 V, 50 Hz, full load)	< 0.5 s
Turn off time (at 230 V, 50 Hz, full load)	< 0.7 s
Hold on time at power failure (output)	0 s
Ambient temperature $t_a$ (at life-time 50,000 h)	35 °C
Storage temperature $t_s$	-40 ... +80 °C
Mains surge capability (between L - N)	1 kV
Mains surge capability (between L/N - PE)	2 kV
Burst / surge peaks output side against PE	< 500 V
Life-time	up to 100,000 h
Dimensions L x W x H	150 x 34 x 38 mm

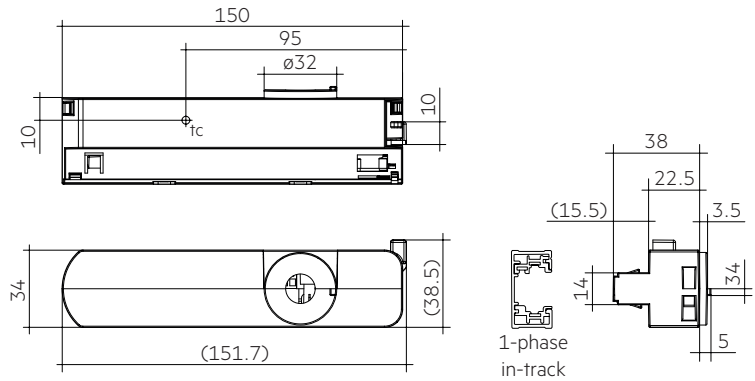

#### Ordering data

Type	Article number	Colour	Packaging, carton	Packaging, pallet	Weight per pc.
LC 38/900/42 fixC T-B SNC	28003364	Black	50 pc(s).	1,200 pc(s).	0.1 kg
LC 38/900/42 fixC T-W SNC	28003359	White	50 pc(s).	1,200 pc(s).	0.1 kg
LC 38/900/42 fixC T-G SNC	28003369	Grey	50 pc(s).	1,200 pc(s).	0.1 kg

#### Specific technical data

Type	Output current <sup>①</sup>	Min. forward voltage	Max. forward voltage	Max. output power	Typ. power consumption (at 230 V, 50 Hz, full load)	Typ. current consumption (at 230 V, 50 Hz, full load)	Max. casing temperature $t_c$	Ambient temperature $t_a$ max.
LC 38/900/42 fixC T SNC	900 mA	30 V	42 V	37.8 W	42 W	190 mA	60 °C	-20 ... +35 °C

<sup>①</sup> Output current is mean value.

<sup>②</sup> Test result at 25 °C.

## 1. Standards

EN 55015  
EN 61000-3-2  
EN 61000-3-3  
EN 61347-1  
EN 61347-2-13  
EN 61547  
EN 61000-4-4  
EN 61000-4-5

### 1.1 Glow-wire test

according to EN 61347-1 with increased temperature of 850 °C passed (Black RAL9005/ White RAL9010).

according to EN 61347-1 with increased temperature of 750 °C passed (Grey RAL7035).

## 2. Thermal details and life-time

### 2.1 Expected life-time

Expected life-time			
Type	ta	25 °C	35 °C
LC 38/900/42 fixC T SNC	tc	50 °C <sup>①</sup>	60 °C <sup>①</sup>
	Life-time	> 125,000 h	> 100,000 h

<sup>①</sup> Test result at max. output voltage.

The LED Drivers are designed for a life-time stated above under reference conditions and with a failure probability of less than 10 %.

Temperatures were measured with Tracktype PRO-310 from manufacturer powergear. Temperatures can deviate with tracks from other manufacturers.

## 3. Installation / wiring

### 3.1 Circuit diagram

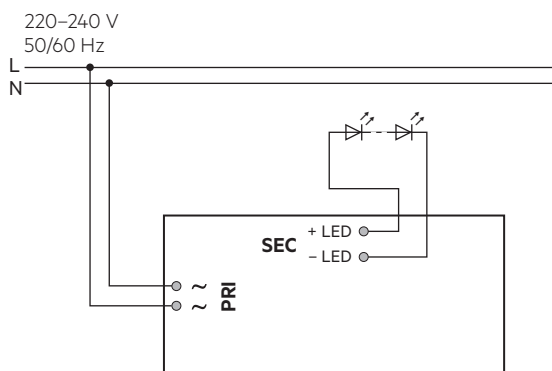

### 3.2 Wiring type and cross section

The wiring can be in stranded wires with ferrules or solid with a cross section of 0.5–1.5 mm<sup>2</sup>. Strip 8.5–9.5 mm of insulation from the cables to ensure perfect operation of the push-wire terminals.

Use one wire for each terminal connector only.

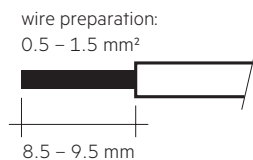

### 3.3 Release of the wiring

Press down the “push button” and remove the cable from front.

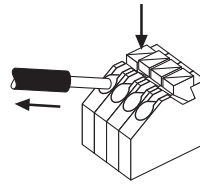

### 3.4 Fixing conditions

Dry, acidfree, oilfree, fatfree. It is not allowed to exceed the maximum ambient temperature (ta) stated on the device.

### 3.5 Wiring guidelines

- All connections must be kept as short as possible to ensure good EMI behaviour.
- Max. length of output wires is 20 cm.
- Secondary switching is not permitted.
- Incorrect wiring can damage LED modules.
- To avoid the damage of the Driver, the wiring must be protected against short circuits to earth (sharp edged metal parts, metal cable clips, louver, etc.).

### 3.6 Replace LED module

1. Mains off
2. Remove LED module
3. Wait for 10 seconds
4. Connect LED module again

Hot plug-in or secondary switching of LEDs is not permitted and may cause a very high current to the LEDs.

### 3.7 Mounting luminaire

Max. allowed weight of complete luminaire: 5 kg (50 N)

### 3.8 Compatible 1-phase tracks

Subject to be changed without notice.

Manufacturer	Type	Casing colour
powergear	PRO-0310-W	white (RAL 9010)
powergear	PRO-0310-S	silver (RAL7040)
powergear	PRO-0310-B	black (RAL9011)
SAL	STR4800/1 WH	1M TRACK, white
SAL	STR4800/1 BK	1M TRACK, black
SAL	STR4800/2 WH	2M TRACK, white
SAL	STR4800/2 BK	2M TRACK, black

Tests have been done with in-tracks taken from the market in the first half of 2018.



Tridonic has no control or responsibility on any future or past possible changes made by different manufactures that could affect the compatibility between tracks and adapters.

### 3.9 Adapter mounting into the track

Insert the adapter into the track, so that the copper connection (B) in the adaptor matches the groove (A) in the track. Rotate of about 90° the lever of the cam (C) until it reaches the locking position. To open rotate the lever the opposite direction.

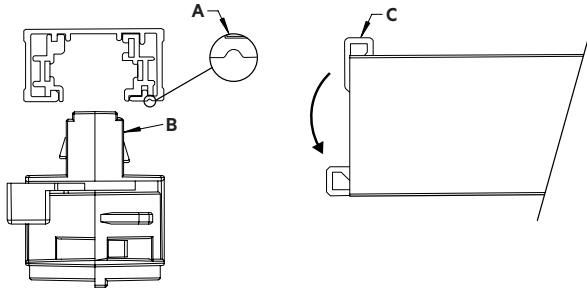

## 4. Electrical values

### 4.1 Efficiency vs load

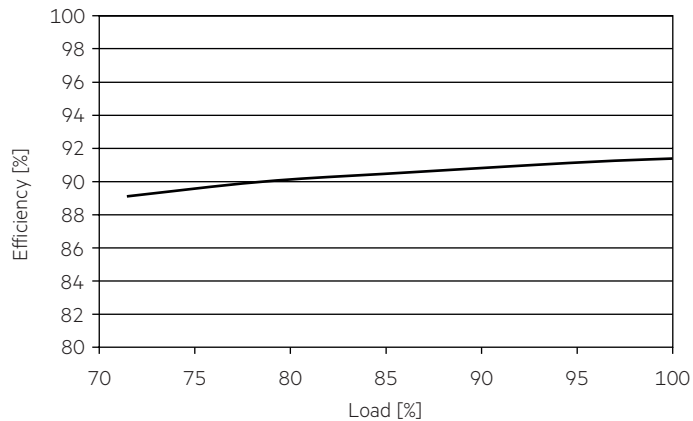

### 4.2 Power factor vs load

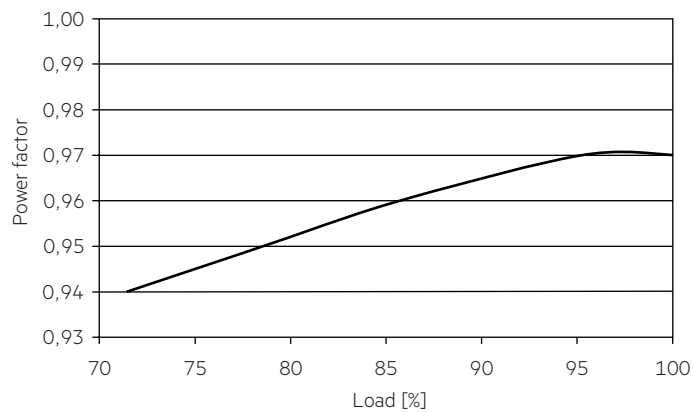

### 4.3 Input power vs load

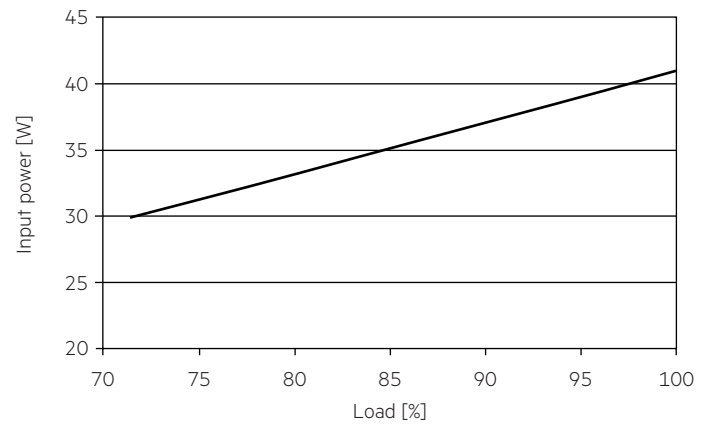

### 4.4 Input current vs load

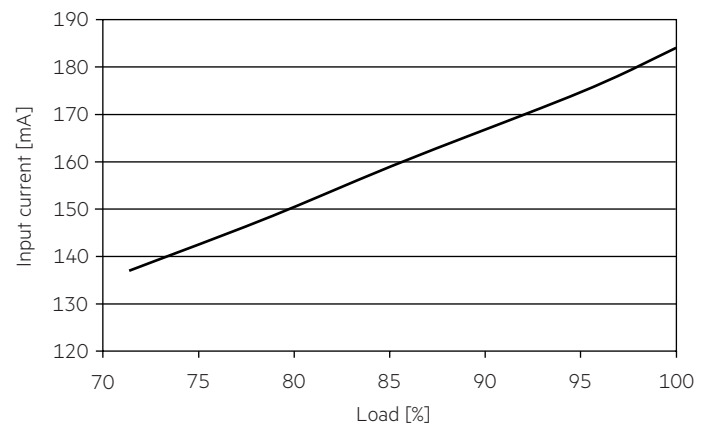

### 4.5 THD vs load

THD without harmonic < 5 mA (0.6 %) of the input current:

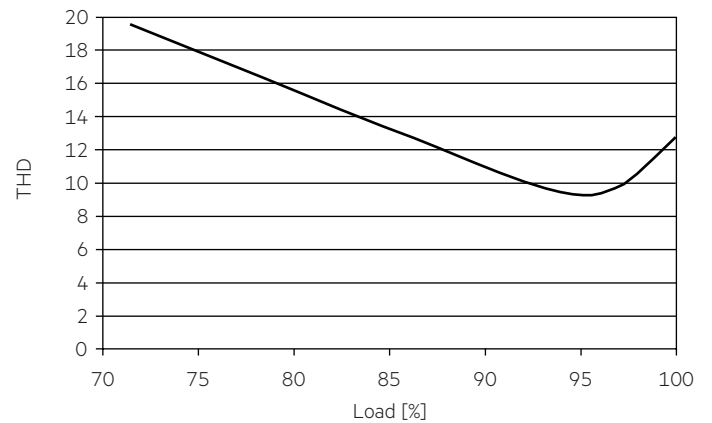

#### 4.6 Maximum loading of automatic circuit breakers in relation to inrush current

Automatic circuit breaker type	C10	C13	C16	C20	B10	B13	B16	B20	Inrush current	
Installation Ø	1.5 mm <sup>2</sup>	1.5 mm <sup>2</sup>	1.5 mm <sup>2</sup>	2.5 mm <sup>2</sup>	1.5 mm <sup>2</sup>	1.5 mm <sup>2</sup>	1.5 mm <sup>2</sup>	2.5 mm <sup>2</sup>	I <sub>max</sub>	Time
<b>LC 38/900/42 fixC T SNC</b>	26	35	41	53	16	21	25	32	26 A	178 µs

This are max. values calculated out of inrush current! Please consider not to exceed the maximum rated continuous current of the circuit breaker. Calculation uses typical values from ABB series S200 as a reference. Actual values may differ due to used circuit breaker types and installation environment.

#### 4.7 Harmonic distortion in the mains supply (at 230 V / 50 Hz and full load) in %

	THD	3.	5.	7.	9.	11.
<b>LC 38/900/42 fixC T SNC</b>	< 15	< 12	< 7	< 5	< 4	< 3

Acc. to 6100-3-2. Harmonics < 5 mA or < 0.6 % (whatever is greater) of the input current are not considered for calculation of THD.

## 5. Functions

### 5.1 Short-circuit behaviour

In case of a short circuit on the secondary side (LED) the LED Driver switches off. After elimination of the short-circuit fault the LED Driver will recover automatically.

### 5.2 No-load operation

The LED Driver works in burst working mode to provide a constant output voltage regulation which allows the application to be able to work safely when LED string opens due to a failure.

### 5.3 Overload protection

If the output voltage range is exceeded, the LED Driver will protect itself and LED may flicker. After elimination of the overload the nominal operation will recover automatically.

## 6. Miscellaneous

### 6.1 Insulation and electric strength testing of luminaires

Electronic devices can be damaged by high voltage. This has to be considered during the routine testing of the luminaires in production.

According to IEC 60598-1 Annex Q (informative only!) or ENEC 303-Annex A, each luminaire should be submitted to an insulation test with 500 V<sub>DC</sub> for 1 second. This test voltage should be connected between the interconnected phase and neutral terminals and the earth terminal. The insulation resistance must be at least 2 MΩ.

As an alternative, IEC 60598-1 Annex Q describes a test of the electrical strength with 1500 V<sub>AC</sub> (or 1.414 x 1500 V<sub>DC</sub>). To avoid damage to the electronic devices this test must not be conducted.

### 6.2 Conditions of use and storage

Humidity: 5 % up to max. 95 %, not condensed (max. 56 days/year at 95 %)

Storage temperature: -40 °C up to max. +80 °C

The devices have to be within the specified temperature range (t<sub>a</sub>) before they can be operated.

### 6.3 Maximum number of switching cycles

All LED Driver are tested with 50,000 switching cycles. The actually achieved number of switching cycles is significantly higher.

### 6.4 Additional information

Additional technical information at [www.tridonic.com](http://www.tridonic.com) → Technical Data

Guarantee conditions at [www.tridonic.com](http://www.tridonic.com) → Services

Life-time declarations are informative and represent no warranty claim. No warranty if device was opened.